

Linux 101

Johan Montelius

KTH

2021

Some history - way back



BESK - KTH 1953, 512 word memory

- - 1960
- Large single job machines, batch processing
- Operating system often only libraries to handle hardware.



PDP-10 - KTH 1970 ca, 256 Kiword memory

- 1970 - 1980
- Multiuser systems, minicomputers (very large)
- Time sharing, virtual memory, hard drives, ...
- Birth of Unix and C



Mac or IBM PC?

- 1980 - 1990
- The personal computer.
- Manual switching between programs.
- MS-DOS, Mac OS, ..



AIX, HP-UX, Solaris, Ultrix ...

- 1980 - 2000
- Unix flavors become the leading operating systems for everything but personal computers.
- Everyone wants a standard - their own.



Gnu is Not Unix

- 1983 -
- Providing a free (as in speech, not beer) operating system with everything you could need.
- Everything was in place ... the kernel will soon be ready.

Hello everybody out there using minix -

I'm doing a (free) operating system (just a hobby, won't be big and professional like gnu) for 386(486) AT clones. : :

PS. Yes - it's free of any minix code, and it has a multi-threaded fs. It is NOT portable (uses 386 task switching etc), and it probably never will support anything other than AT-harddisks, as that's all I have :-).

- Linus Torvalds



Linux - the kernel for GNU

- 1993 -
- Linus Torvalds
- A monolithic system targeting the Intel 386 CPU.
- Linux was born and became the kernel for GNU.

The Unix Family

MULTICS MIT/GE/Bell Labs

The Unix Family

MULTICS MIT/GE/Bell Labs

UNIX AT&T (Bell Labs)

The Unix Family

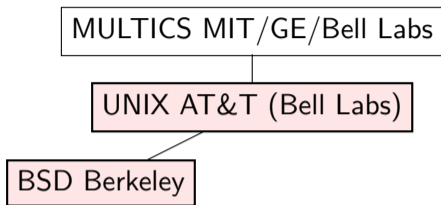

The Unix Family

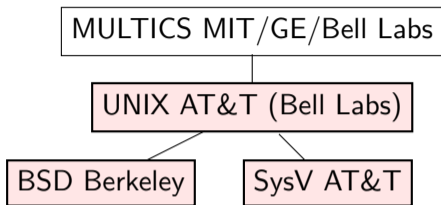

The Unix Family

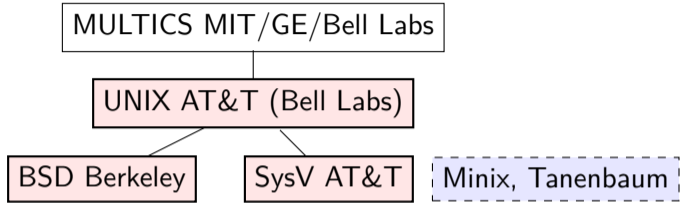

The Unix Family

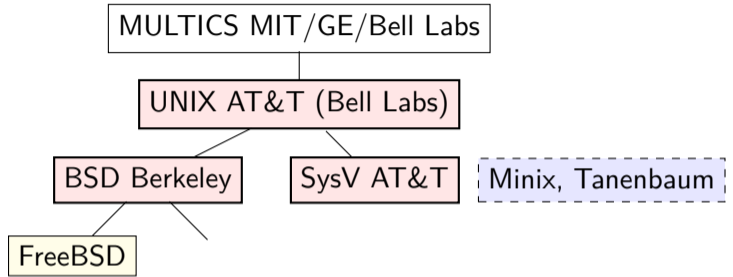

The Unix Family

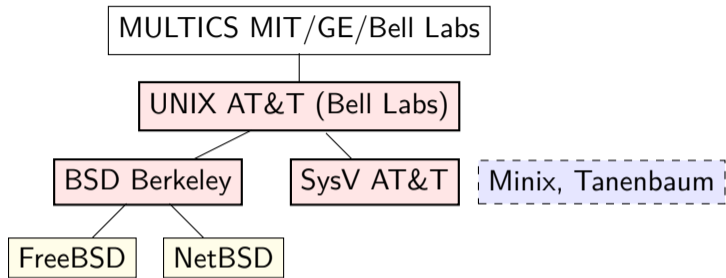

The Unix Family

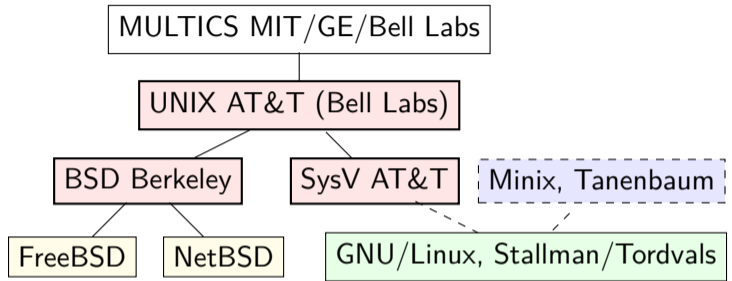

The Unix Family

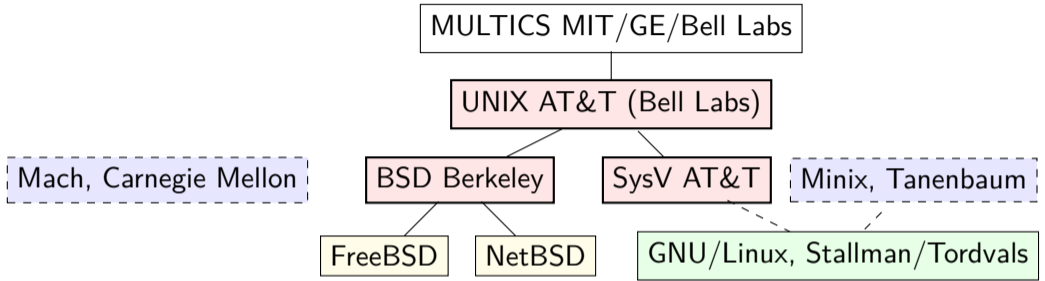

The Unix Family

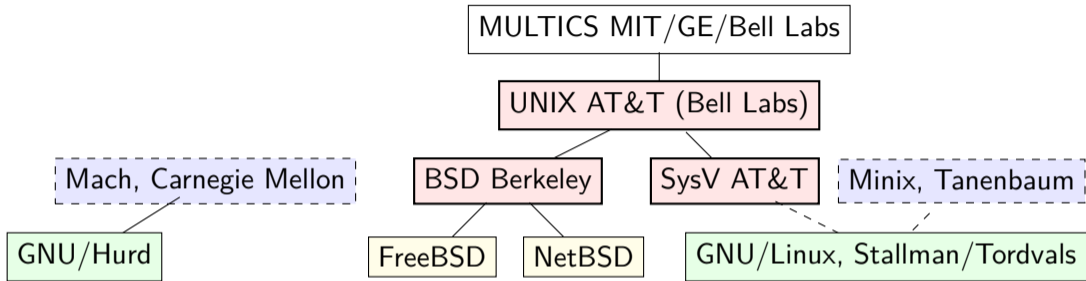

The Unix Family

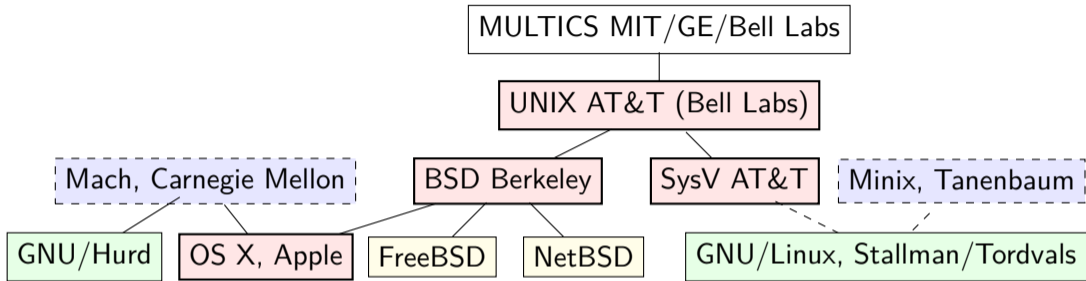

The Unix Family

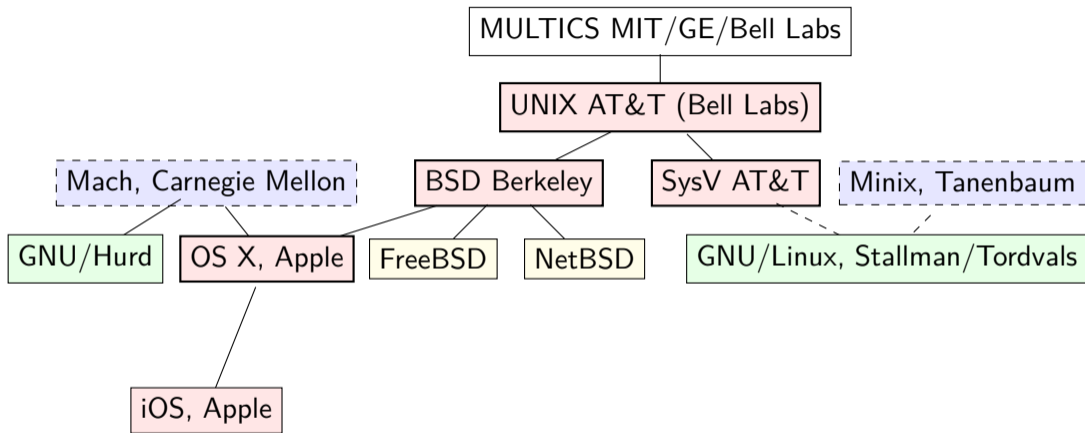

The Unix Family

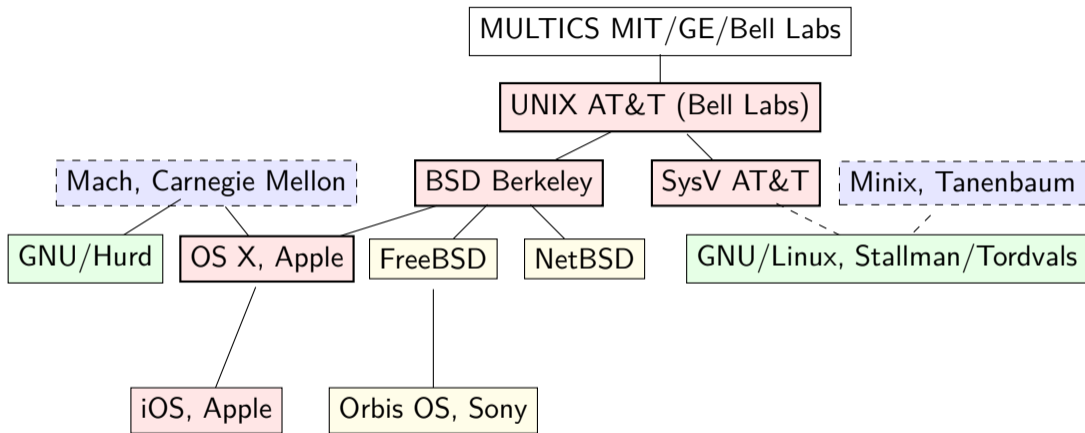

The Unix Family

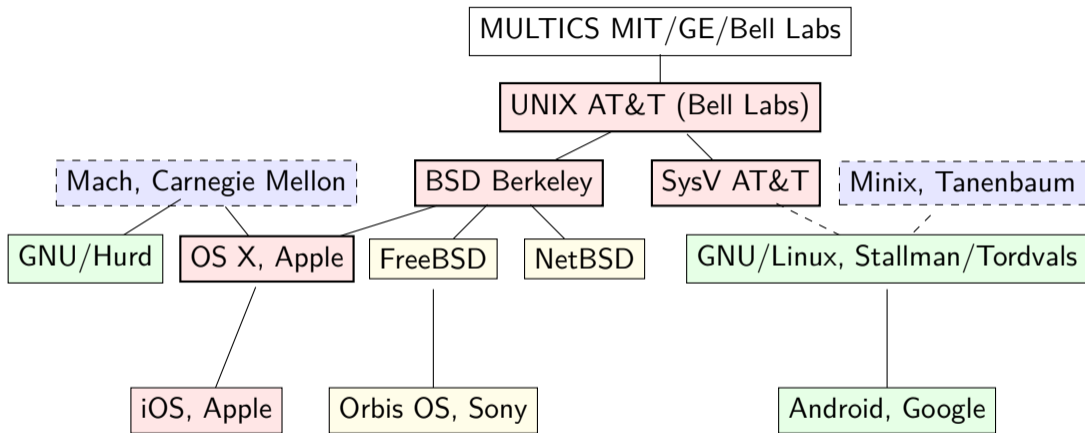

The Unix Family

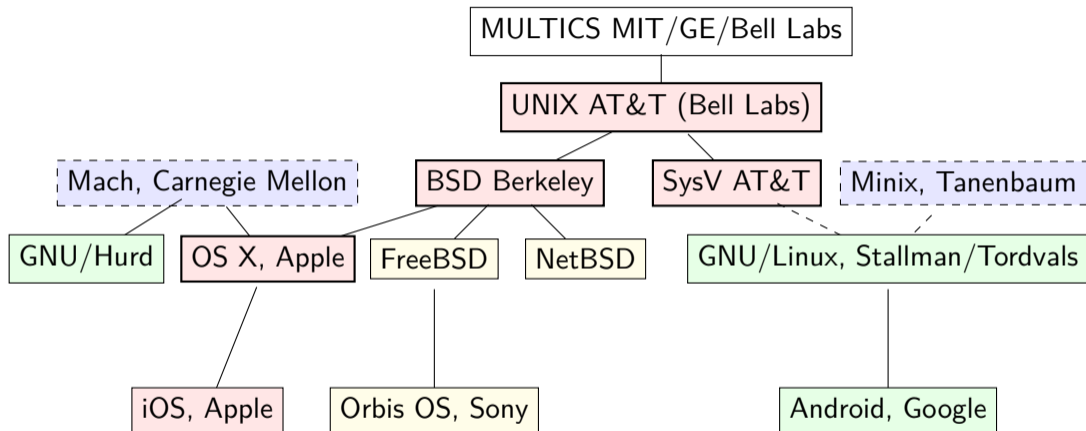

.. left out a hundred other systems.

Even more

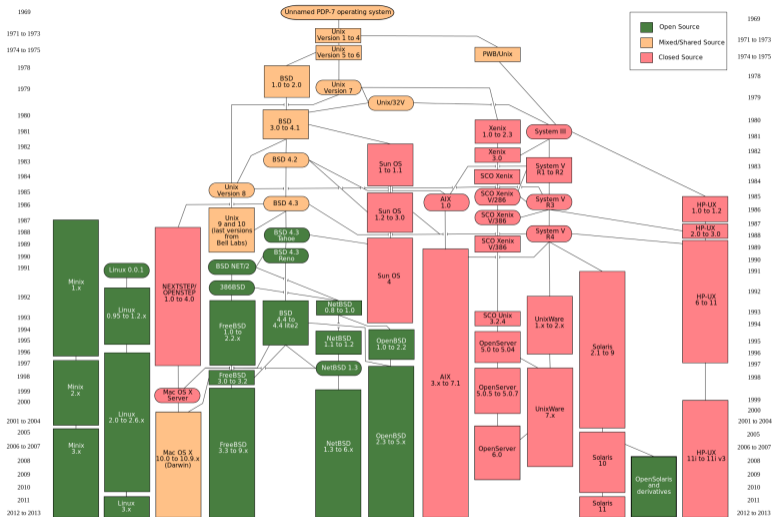
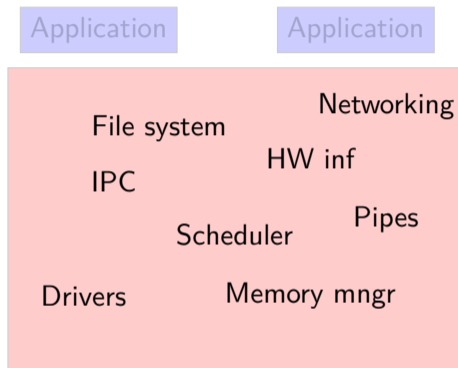

Figure: from www.levenez.com/unix/history.html

Monolithic vs Microkernel



One large monolithic kernel.
Linux, BSD, MacOS,

Monolithic vs Microkernel

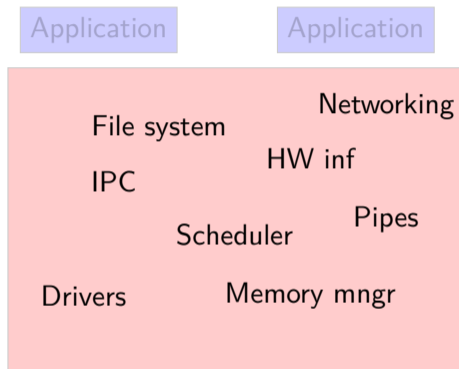

One large monolithic kernel.
Linux, BSD, MacOS,

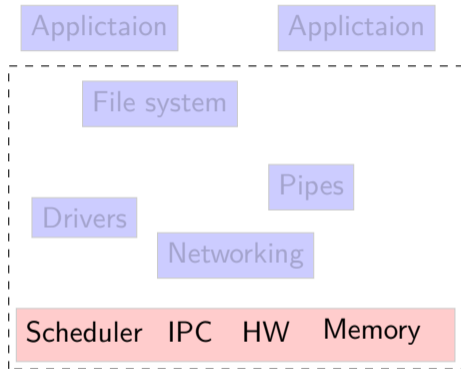

A minimal kernel.

Monolithic vs Microkernel

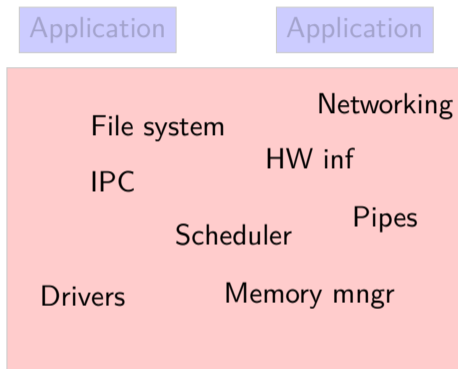

One large monolithic kernel.
Linux, BSD, MacOS,

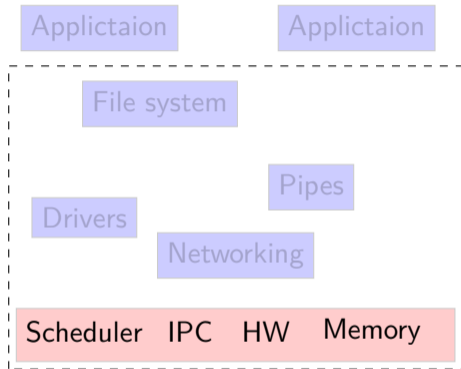

A minimal kernel.
Minix, Mach, L4 ... (Windows/NT)

The kernel will not get you far, you will need: drivers, file system, network, security, codecs, window manager, compilers, browsers, office, games . . .

The kernel will not get you far, you will need: drivers, file system, network, security, codecs, window manager, compilers, browsers, office, games . . .

You can, but few do, download and compile exactly the components that you want . . . few people do that.

The kernel will not get you far, you will need: drivers, file system, network, security, codecs, window manager, compilers, browsers, office, games . . .

You can, but few do, download and compile exactly the components that you want . . . few people do that.

- **Debian:** the base for many - Ubuntu, Mint . . . most popular

The kernel will not get you far, you will need: drivers, file system, network, security, codecs, window manager, compilers, browsers, office, games . . .

You can, but few do, download and compile exactly the components that you want . . . few people do that.

- **Debian:** the base for many - Ubuntu, Mint . . . most popular
- **Fedora:** used by Linus, Red Hat commercial version, CentOS . . .

The kernel will not get you far, you will need: drivers, file system, network, security, codecs, window manager, compilers, browsers, office, games . . .

You can, but few do, download and compile exactly the components that you want . . . few people do that.

- **Debian:** the base for many - Ubuntu, Mint . . . most popular
- **Fedora:** used by Linus, Red Hat commercial version, CentOS . . .
- **Mandriva:** a.k.a Mandrake, Red Hat offspring, KDE, Intel only

The kernel will not get you far, you will need: drivers, file system, network, security, codecs, window manager, compilers, browsers, office, games . . .

You can, but few do, download and compile exactly the components that you want . . . few people do that.

- **Debian**: the base for many - Ubuntu, Mint . . . most popular
- **Fedora**: used by Linus, Red Hat commercial version, CentOS . . .
- **Mandriva**: a.k.a Mandrake, Red Hat offspring, KDE, Intel only
- **openSUSE**: supported by Novell, second most popular distro

The kernel will not get you far, you will need: drivers, file system, network, security, codecs, window manager, compilers, browsers, office, games . . .

You can, but few do, download and compile exactly the components that you want . . . few people do that.

- **Debian**: the base for many - Ubuntu, Mint . . . most popular
- **Fedora**: used by Linus, Red Hat commercial version, CentOS . . .
- **Mandriva**: a.k.a Mandrake, Red Hat offspring, KDE, Intel only
- **openSUSE**: supported by Novell, second most popular distro
- **GenToo**: BSD like, professional users

The kernel will not get you far, you will need: drivers, file system, network, security, codecs, window manager, compilers, browsers, office, games . . .

You can, but few do, download and compile exactly the components that you want . . . few people do that.

- **Debian**: the base for many - Ubuntu, Mint . . . most popular
- **Fedora**: used by Linus, Red Hat commercial version, CentOS . . .
- **Mandriva**: a.k.a Mandrake, Red Hat offspring, KDE, Intel only
- **openSUSE**: supported by Novell, second most popular distro
- **GenToo**: BSD like, professional users
- **Arch Linux**: for advanced users, Antergos, KaOS, Manjaro

The kernel will not get you far, you will need: drivers, file system, network, security, codecs, window manager, compilers, browsers, office, games . . .

You can, but few do, download and compile exactly the components that you want . . . few people do that.

- **Debian**: the base for many - Ubuntu, Mint . . . most popular
- **Fedora**: used by Linus, Red Hat commercial version, CentOS . . .
- **Mandriva**: a.k.a Mandrake, Red Hat offspring, KDE, Intel only
- **openSUSE**: supported by Novell, second most popular distro
- **GenToo**: BSD like, professional users
- **Arch Linux**: for advanced users, Antergos, KaOS, Manjaro
- **Slackware**: you'll learn a lot





- Supported by Canonical
- Based on Debian packages.
- Two regular releases a year :04 and :10
- LTS - five year support, released every second year
- Things work and are easy to maintain.

Ubuntu, Kubuntu, Lubuntu,....

Which version of Ubuntu to choose is very much a choice of desktop environment.

Ubuntu, Kubuntu, Lubuntu,....

Which version of Ubuntu to choose is very much a choice of desktop environment.

Ubuntu, Kubuntu, Lubuntu,....

Which version of Ubuntu to choose is very much a choice of desktop environment.

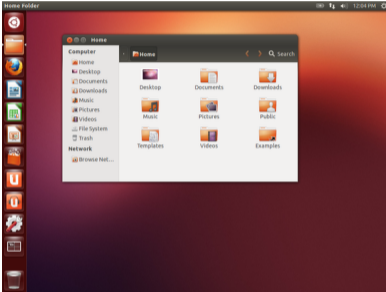

Ubuntu, Kubuntu, Lubuntu,....

Which version of Ubuntu to choose is very much a choice of desktop environment.



Ubuntu, Kubuntu, Lubuntu,....

Which version of Ubuntu to choose is very much a choice of desktop environment.

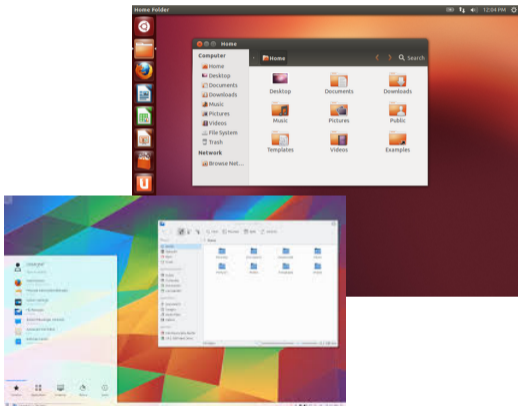

Ubuntu, Kubuntu, Lubuntu,....

Which version of Ubuntu to choose is very much a choice of desktop environment.

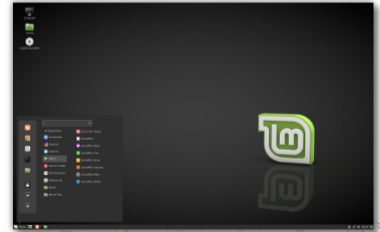
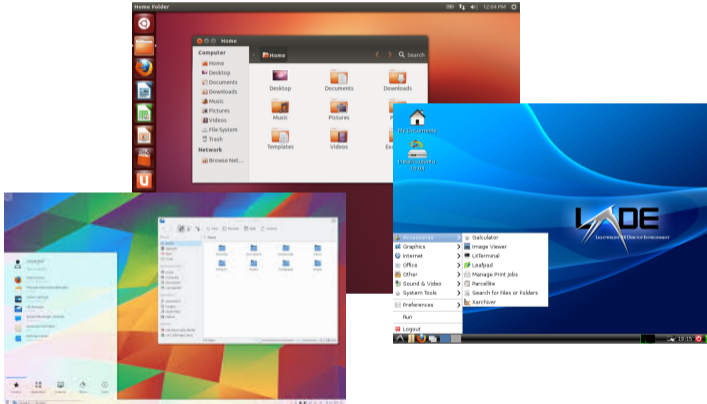

Ubuntu, Kubuntu, Lubuntu,....

Which version of Ubuntu to choose is very much a choice of desktop environment.

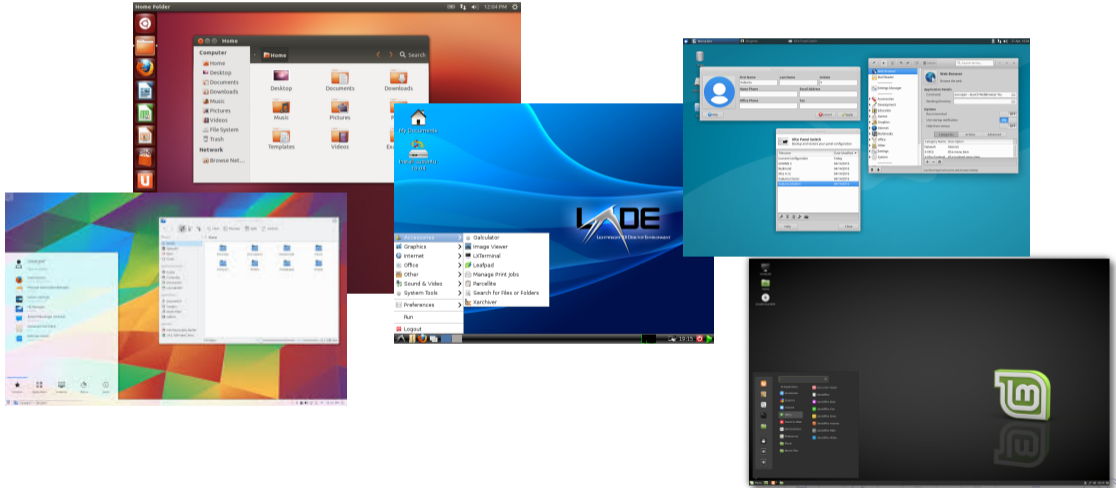

Ubuntu, Kubuntu, Lubuntu,....

Which version of Ubuntu to choose is very much a choice of desktop environment.

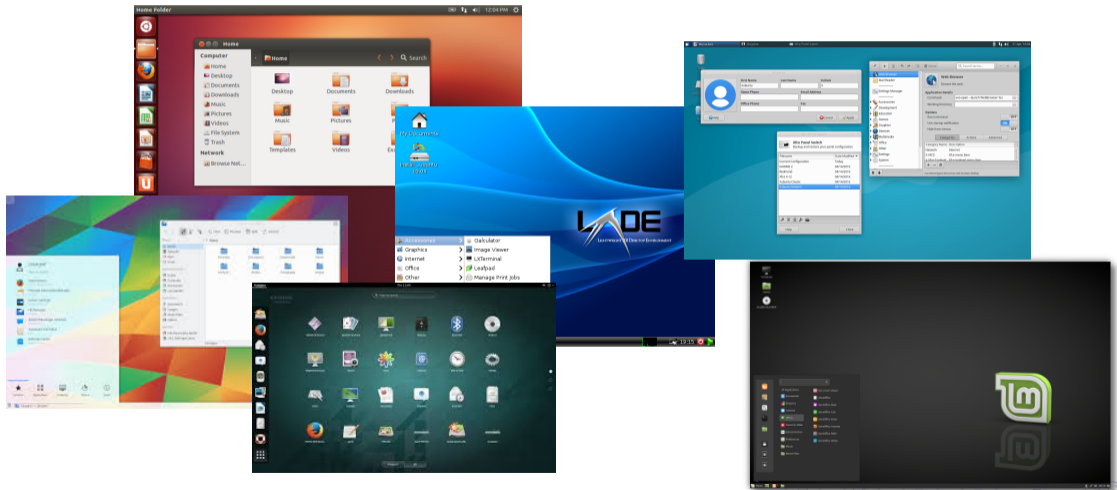

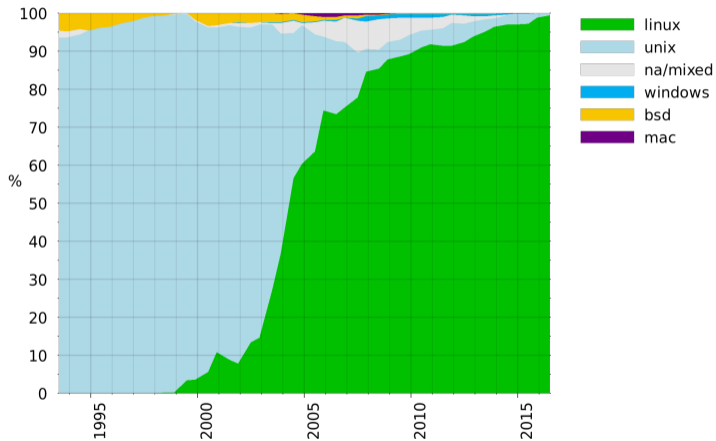

Share of Top500 Super Computers



What's next

What's next

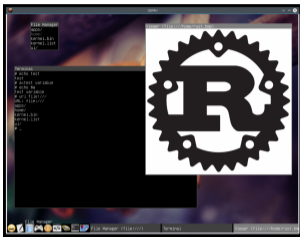

What's next

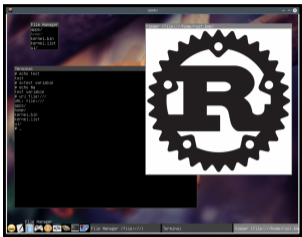

What's next

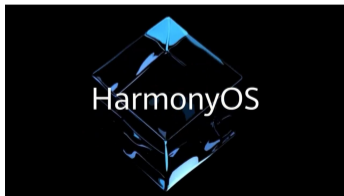
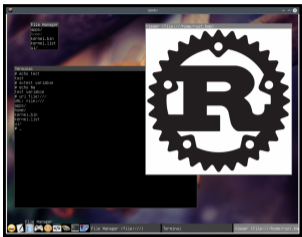

the elephant in the room

the elephant in the room

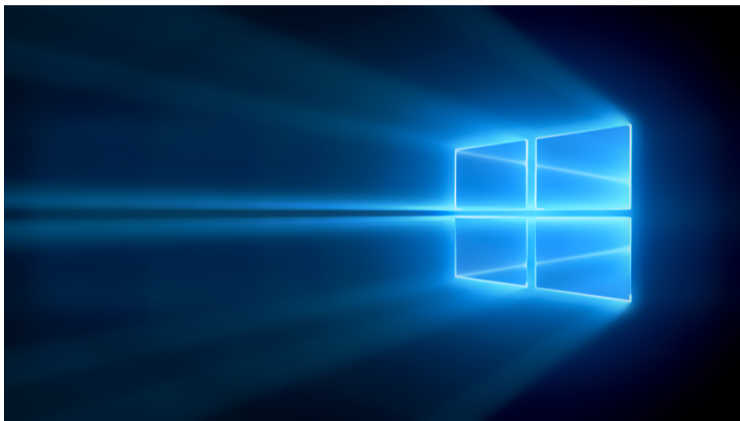

Three options:

Three options:

- Install a *virtual machine* on top of your regular system.

Three options:

- Install a *virtual machine* on top of your regular system.
- Take an old laptop and boot it from scratch.

Three options:

- Install a *virtual machine* on top of your regular system.
- Take an old laptop and boot it from scratch.
- Join the good side.