

# Advanced Logic Design (IL2209) Final Exam

**Student's Name:**

**PN:**

**Date:** December 17, 2010, 9:00 - 13:00

**Examiner:** Elena Dubrova

**Maximum number of points:** 50

**Number of points received:**

**Grade:**

**Grading scheme:**

47-50 A

43-46 B

39-42 C

35-38 D

30-34 E

< 30 F

**What is allowed on the exam:** Nothing except a pen, a pencil, and an eraser

**(2 pt)** 1) Let  $A = \{0, 1\}^3$  and  $B = \{1, 2\}^2$ . Suppose we define a binary relation  $R$  between  $A$  and  $B$  as:

$(a, b) \in R$  if and only if the number of 1's in  $a$  and  $b$  is different

where  $a \in A$  and  $b \in B$ .

1) List all pairs  $(a, b)$  belonging to  $R$ .

2) Is  $R$  a function?

3) Is  $R$  an operation?

(4 pt) 2) Let  $c_1 = (1 - 0 -)$  and  $c_2 = (-1 - 1)$ .

1) Is  $c_1$  contained in  $c_2$ ?

2) Compute the intersection of  $c_1$  and  $c_2$ .

3) Compute the supercube of  $c_1$  and  $c_2$ .

4) Compute the complement of the intersection of  $c_1$  and  $c_2$ .

5) Compute the complement of the supercube of  $c_1$  and  $c_2$ .

6) Compute the complement of the union of  $c_1$  and  $c_2$ .

7) Write  $c_1$  and  $c_2$  in the parallel encoding ((min,max) pairs):

8) Write  $c_1$  and  $c_2$  in the sequential encoding

(7 pt) 3) Answer the questions about the following circuit:

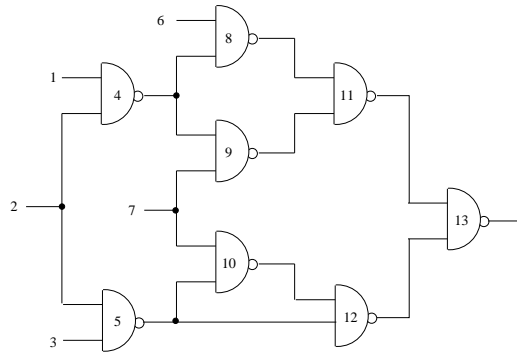

1) Draw its dominator tree (for single-vertex dominators).

(2) Is  $\{5, 8\}$  a 2-vertex dominator for 2?

(3) Is  $\{5, 8, 9\}$  a 3-vertex dominator for 2?

(4) Is  $\{4, 10\}$  a 2-vertex dominator for 2?

(5) Is  $\{4, 11, 12\}$  a 3-vertex dominator for 2?

(5 pt) 4) Build the ROBDD for the ordering  $x_1, x_2, x_3, x_4$  for the following Boolean function:

$x_3x_4 \backslash x_1x_2$	00	01	11	10
00	0	0	1	1
01	1	1	1	1
11	1	1	0	0
10	0	1	0	1

(7 pt) 5) Two ROBDDs shown below have a different variable order. Do they represent the same function? If the answer is “yes”, draw in the space below 1 Karnaugh map for the function which they represent. If the answer is “no”, draw 2 Karnaugh maps for the two functions which they represent.

(3 pt) 6) Consider a Boolean function  $f : \{0, 1\}^4 \rightarrow \{0, 1\}$  whose on-set is given by

$\{0001, 0100, 0101, 0110, 1100, 1101, 1001, 0011\}$

1) List all prime implicants.

2) List all essential prime implicants.

3) Is the cover consisting of all prime implicants irredundant? If the answer is “no”, show which implicant(s) need to be removed to make the cover irredundant.

(7 pt) 7) Draw the composition tree for the 4-variable Boolean function given below. Write the expression for the resulting disjoint decomposition of  $f$ .

$x_3x_4 \backslash x_1x_2$	00	01	11	10
00	0	0	1	0
01	1	1	1	1
11	1	1	1	1
10	0	0	0	1



**(5 pt)** 8) Find all kernels for the following Boolean function

$$f = abc + abe + acde + bce + gc$$

Write the function in a factorized form which minimizes the number of literals.

**(5 pt)** 9) Compute the Reed-Muller canonical form for the following Boolean function

$$f = x_1x_2 + x'_1x_3 + x'_1x'_2x'_3$$

Write the resulting Reed-Muller canonical expression.

(5 pt) 10) Express the following function in the sum-of-product form over Post algebra:

$x_2$	$x_1$	0	1	2	3
0	0	0	0	2	1
1	0	0	0	2	2
2	0	3	3	3	1
3	1	3	2	2	2

1) Use single literals.

2) Use set-literals.